

ABOUT US

PAISLEY, DERRY-LONDONDERRY, CAERNARFON, LUTON, HULL

*“Immerse audiences in the history of the universe
through animation, poetry and music.”*

BBC News



ABOUT US

CAERNARFON, DERRY-LONDONDERRY, HULL, LUTON, PAISLEY

About Us is a large scale public art event combining multimedia installations with animation, poetry, original music and live performance to explore the myriad connections between us, our planet, and the wider cosmos. The live show uses animation and projection mapping to transform buildings and landmarks in five towns and cities across the UK into vast canvases on which we tell the story of 13.8 billion years of hyper-connected history. The show features an original score by composer Nitin Sawhney which is performed by local choirs. The outdoor installation incorporates submissions from a UK-wide poetry and computer coding competition for children and young people run by our partner organisations The Poetry Society and Stemettes. About Us toured the UK from March to May 2022 and ran for a week in each location, with multimedia installations open throughout the day and multiple free performances every evening.

About Us was presented as part of UNBOXED: Creativity in the UK, a celebration of creativity taking place across the UK in 2022, designed to reach millions and bring people together. It featured free large-scale events, installations and globally accessible digital experiences in the UK's most ambitious showcase of creative collaboration.

TYPE	Events & Ceremonies
LOCATION	Paisley, Derry-Londonderry, Caernarfon, Luton, Hull
PROJECT SERVICES	Direction, Video Design, Sound Design, Lighting Design, Content Production, Animation, Technical Design, Sound & Video Programming, Production Management, Event Management



About Us, Projection & Choir, Paisley, Photo: Justin Sutcliffe



About Us, Projection & Plinths, Derry-Londonderry, Photo: Justin Sutcliffe

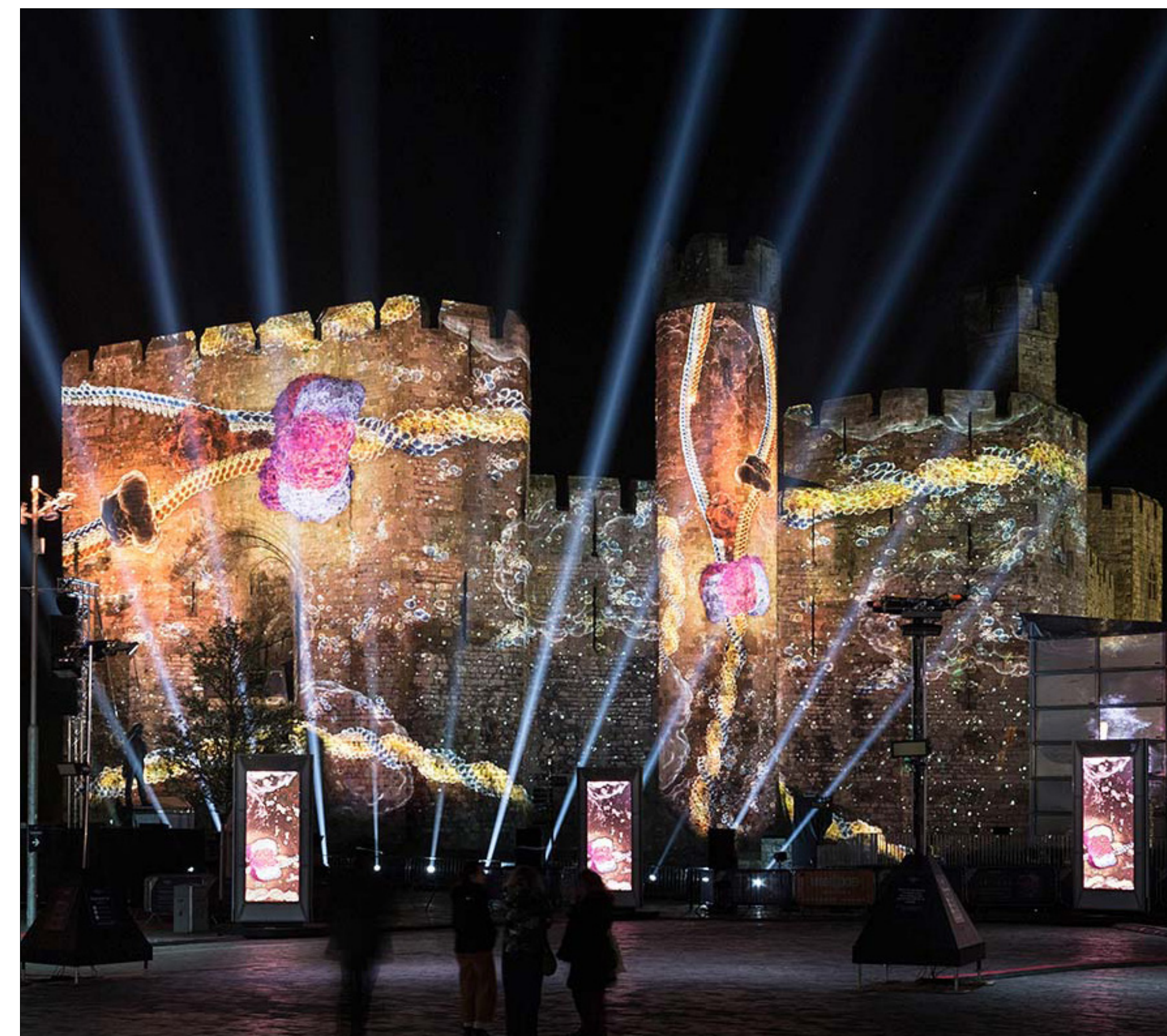

About Us, Projection & Plinths, Caernarfon, Photo: Justin Sutcliffe



About Us, Projection, Choir & Plinths, Luton, Photo: Justin Sutcliffe



About Us, Projection & Plinths, Hull, Photo: Justin Sutcliffe

LINK

SHOW LOCATIONS

PAISLEY, DERRY-LONDONDERRY, CAERNARFON, LUTON, HULL

PAISLEY



DERRY-LONDONDERRY



CAERNARFON



LUTON



HULL



CREATIVE APPROACH
MULTI SENSORY EVENING SHOW

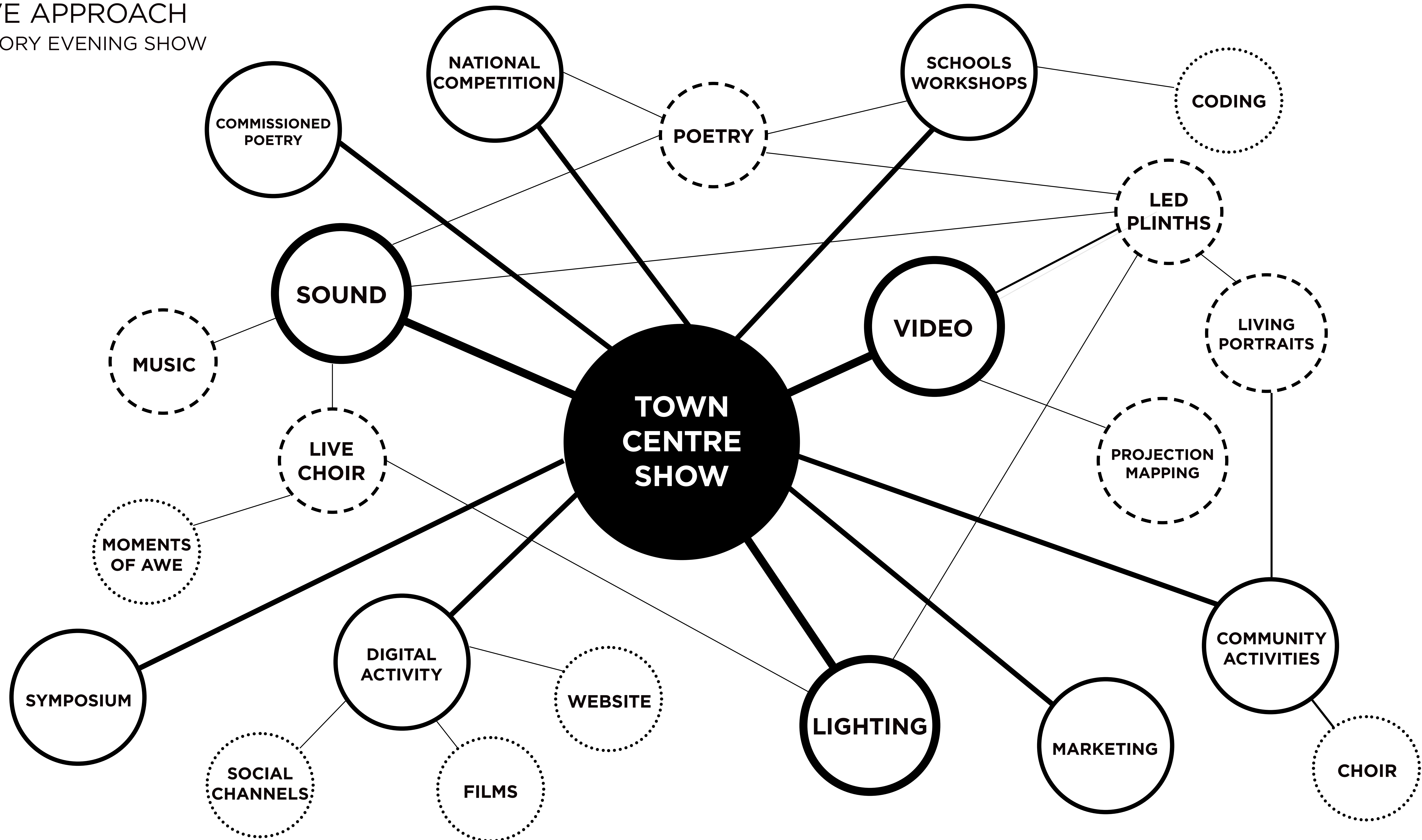

*“Take a thrilling ride through 13.8 billion years of life,
the universe and everything in it”*



PROJECTION MAPPING

CHAPTER OUTLINE

CHAPTER 1
THE BIG BANG

CHAPTER 2
LIFE

CHAPTER 3
NATURE

CHAPTER 4
HUMANS

CHAPTER 5
NOW

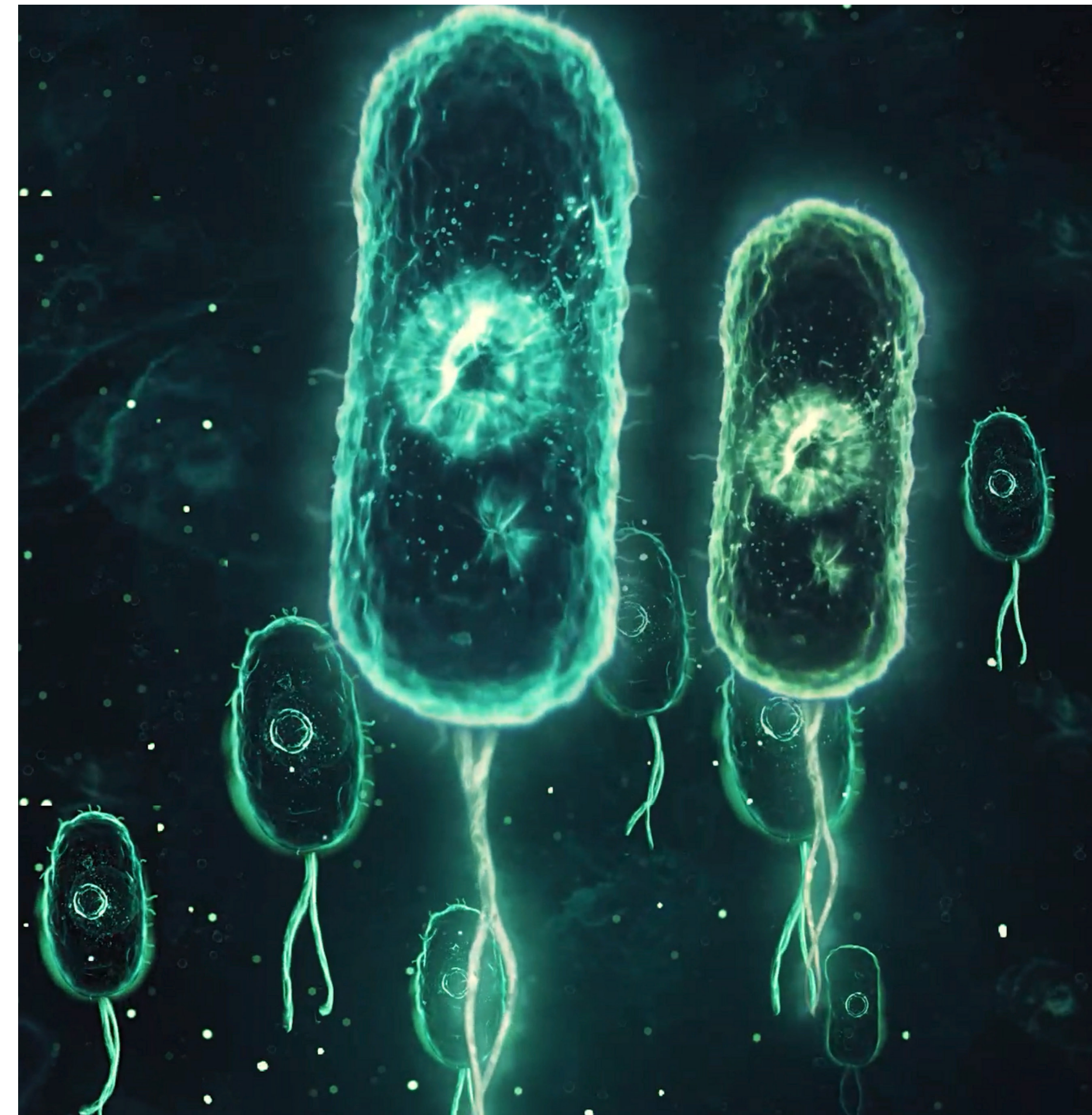
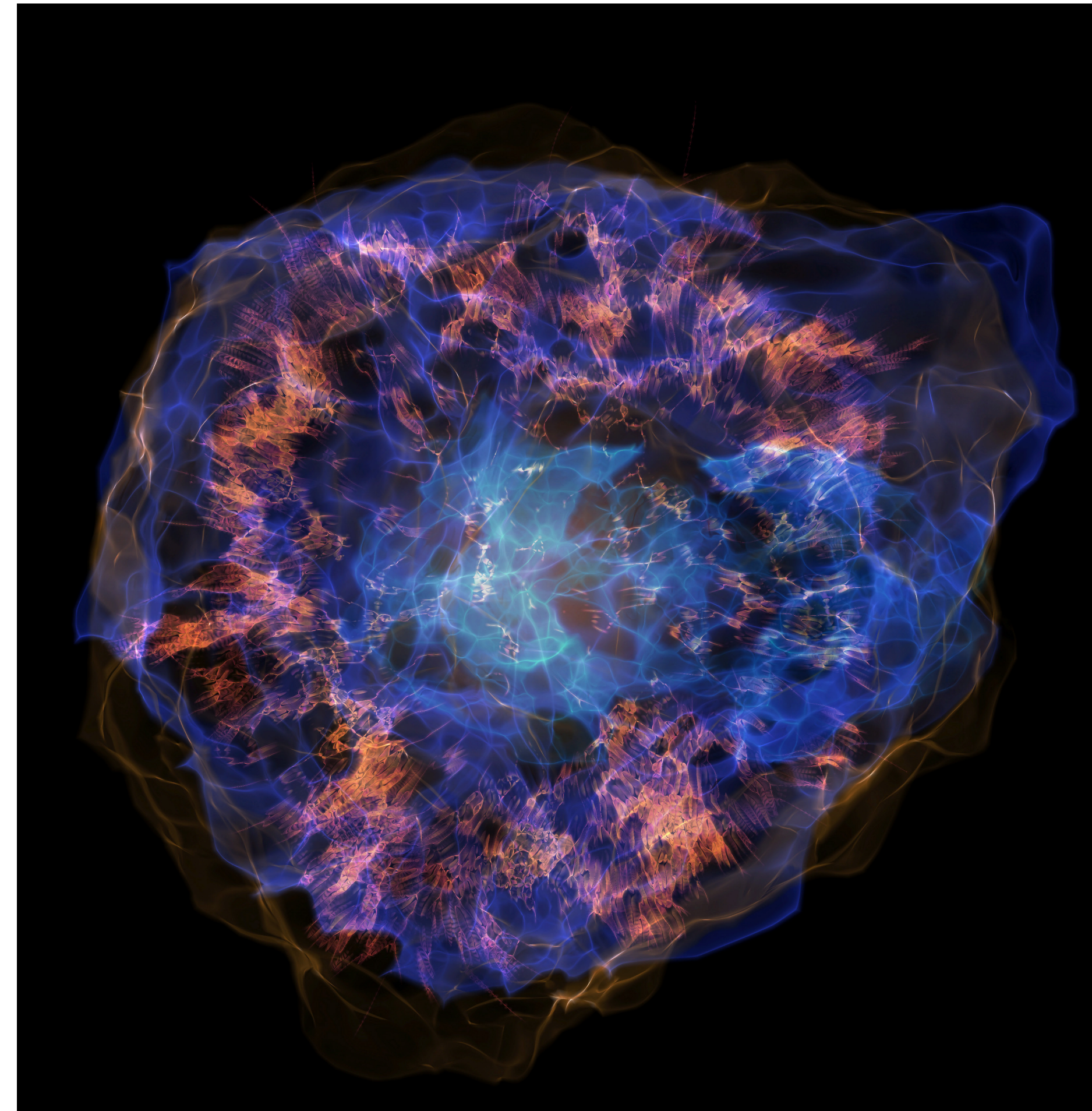

VIDEO CONTENT DAYTIME SHOW

The daytime show brought together the creative results of a wide-reaching community and schools engagement programme, which took place in collaboration with local organisations and facilitators in each of the five show locations. Using our video plinths as a canvas, the daytime programme featured poems written by local young people, slow-motion video portraits of the residents of each town and city, and the winning entries from a national poetry and coding competition.



About Us Promotion



Living Portrait Content



Fact/Awe Campaign



School's Poetry Competition

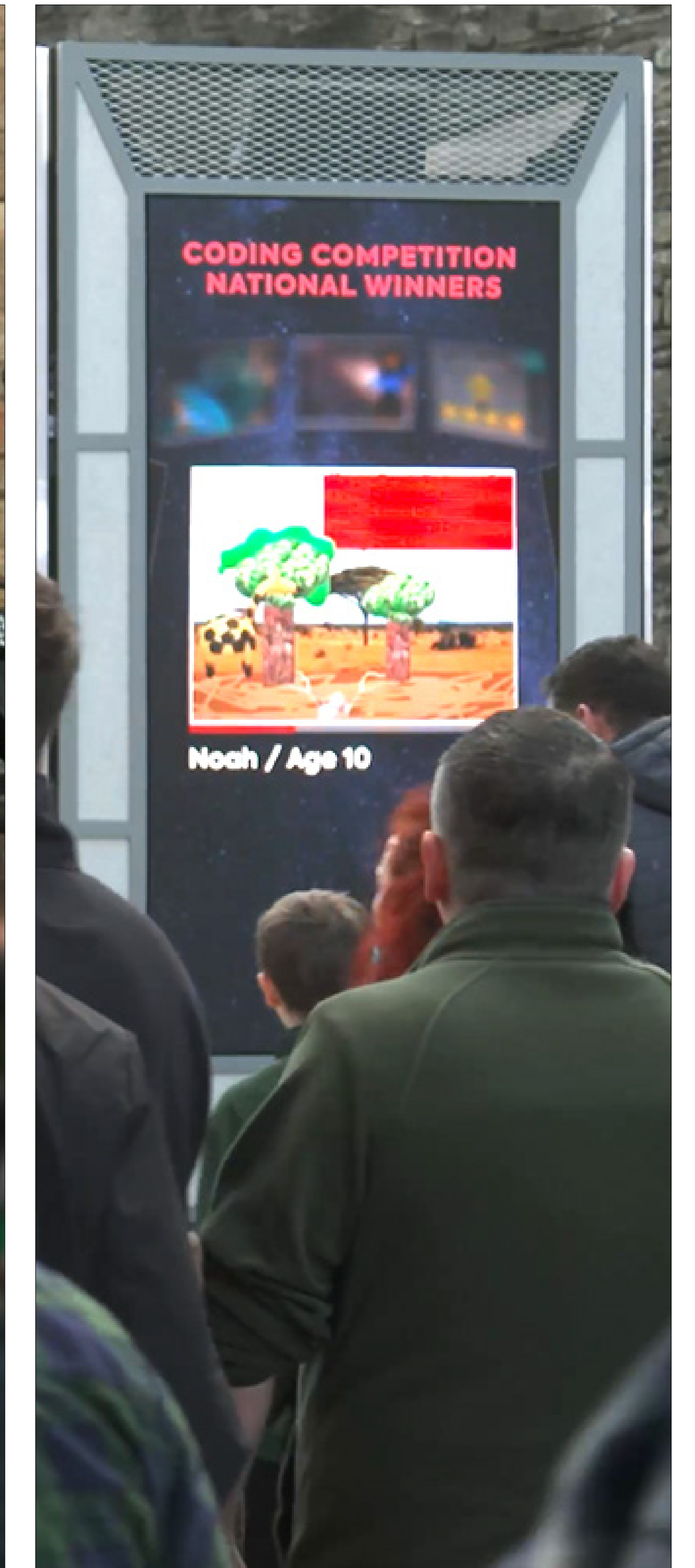

School's Scratch Project

SELECTING SURFACES

PROJECTION SURFACES

PAISLEY



DERRY



CAERNARFON



LUTON



HULL



PROJECTION

AUGMENTING THE URBAN FABRIC

The show was adapted in each of the 5 locations to map specifically to the architecture in each space. From 1 key building in Paisley to 5 different buildings in Hull, the show can grow and expand to fit any size location. Due to its adaptable nature the show can be re-worked for a myriad of surfaces.

The Lighting, LED and projection worked harmoniously to ensure that the lighting was striking and impactful without overpowering the projection surfaces, each element coming in to its own at key storytelling moments.



About Us, Paisley, 2022

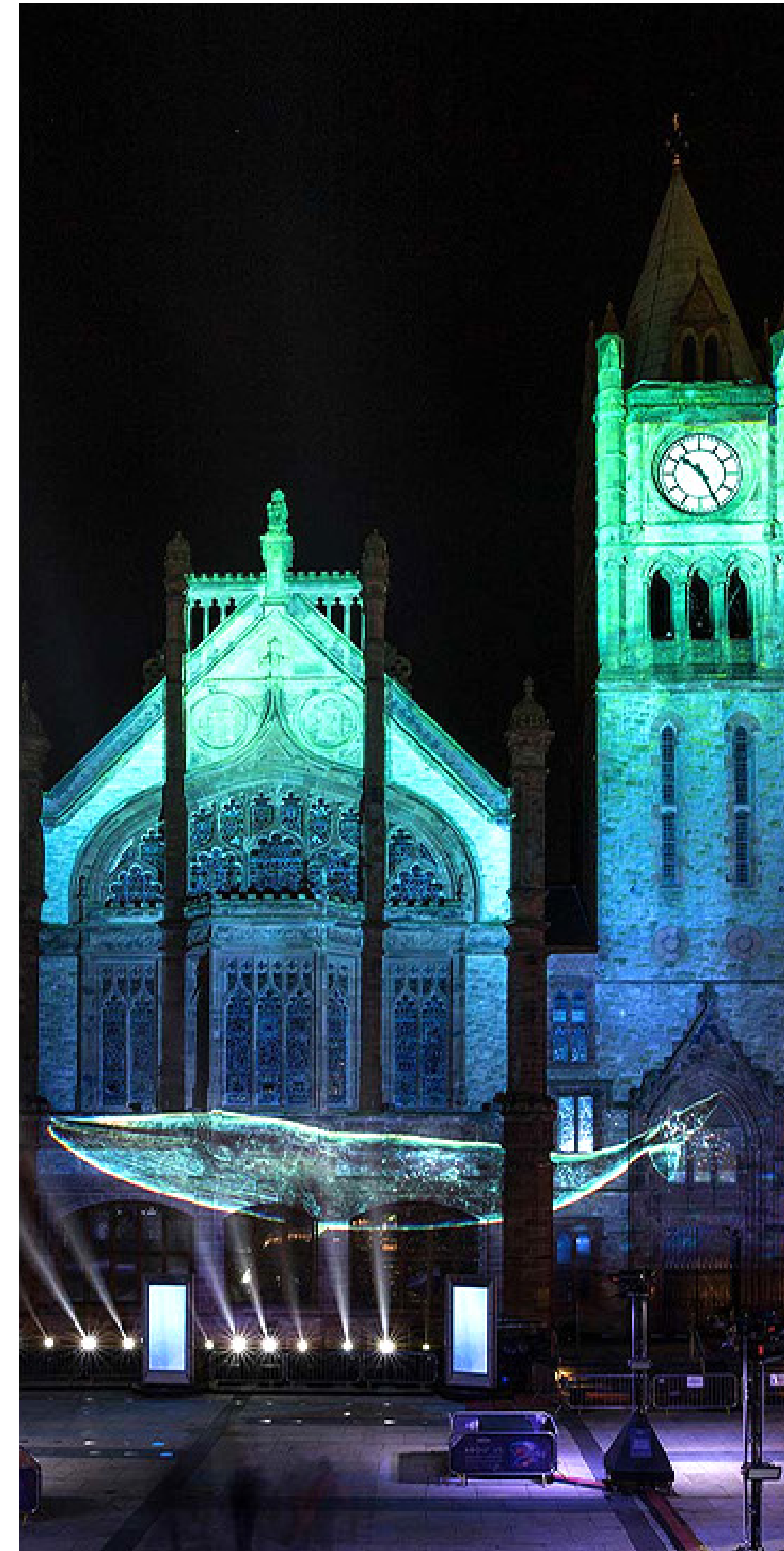

About Us, Derry-Londonderry, 2022

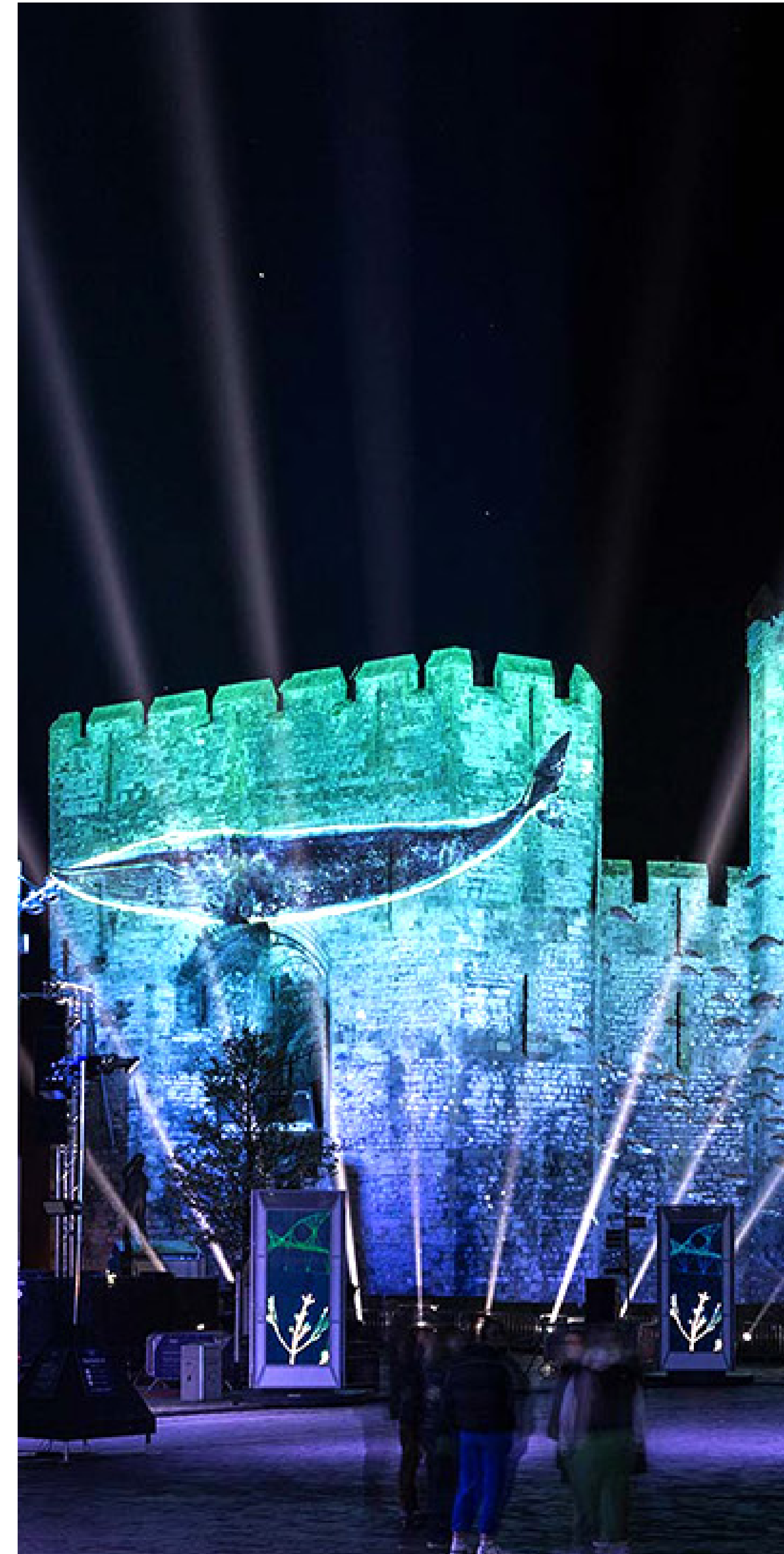

About Us, Caernarfon, 2022

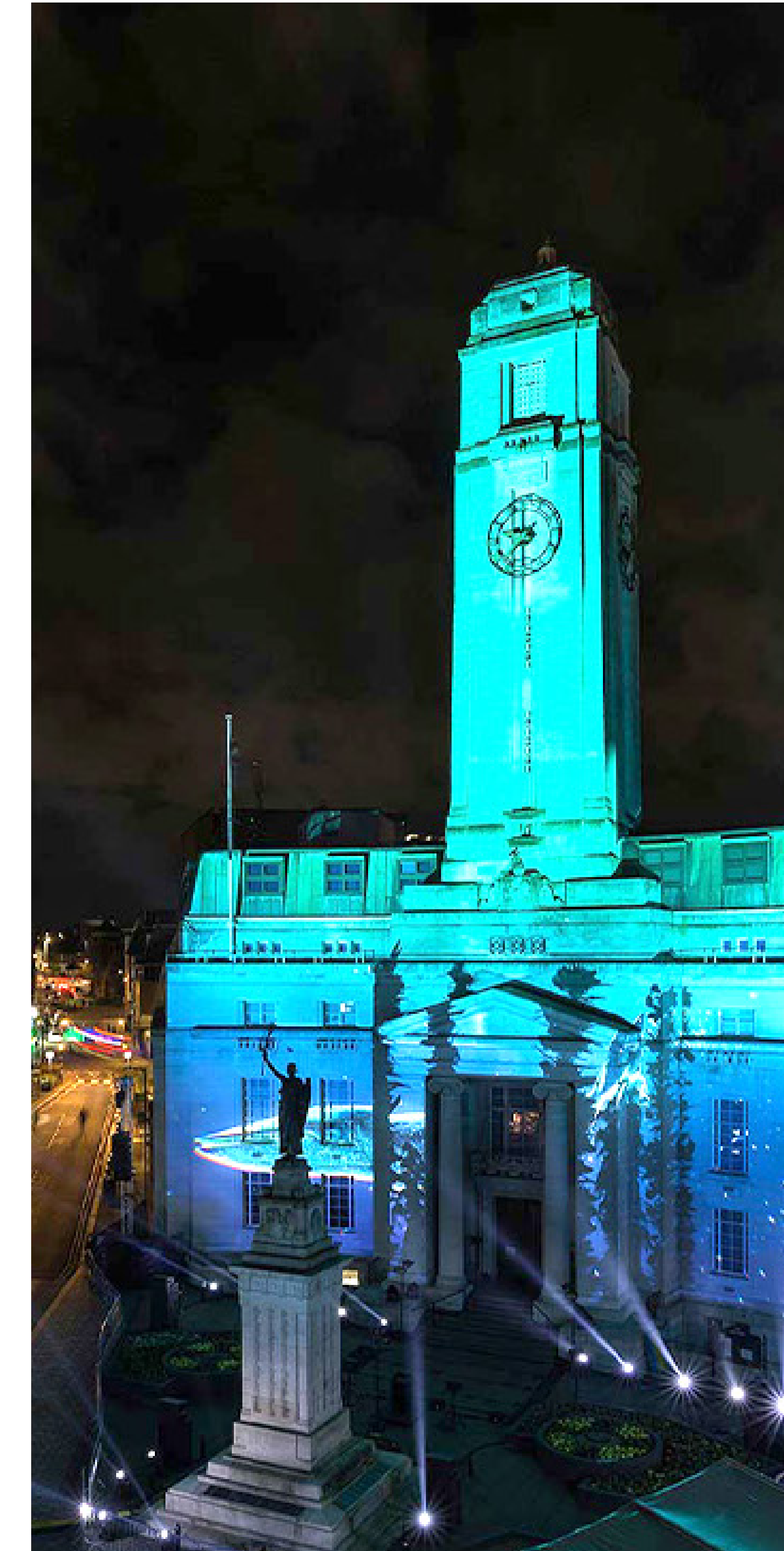

About Us, Luton, 2022

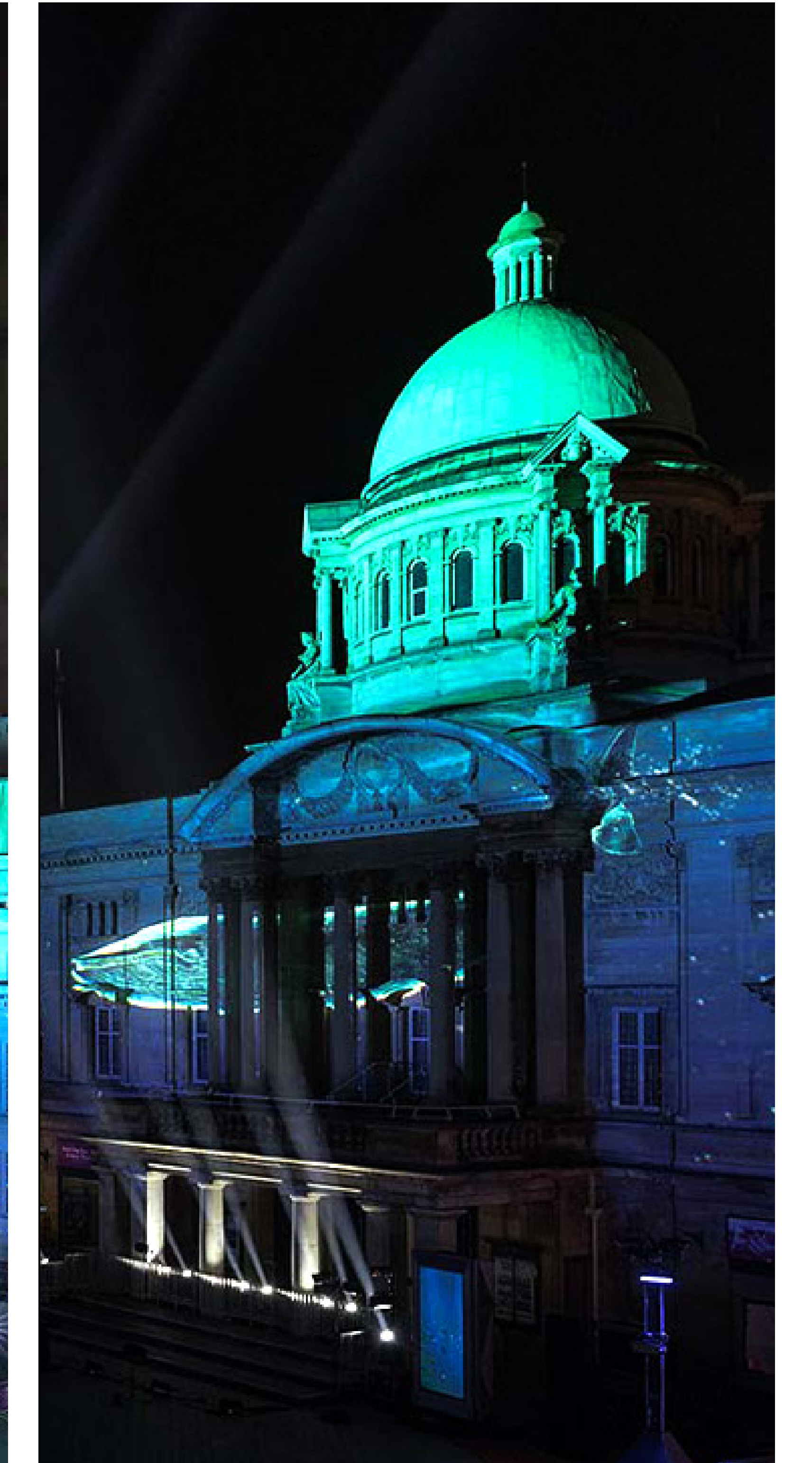

About Us, Hull, 2022

PROJECTION MAPPING

DESIGNING THE DESTINATION

SITE ZONING



ZONE 1: THE PORTAL
BILLBOARD SCALE PLINTHS

ZONE 2: THE JOURNEY
HUMAN SCALE LED PLINTHS

ZONE 3: THE DESTINATION
CENTRAL PLINTHS AND PROJECTIONS

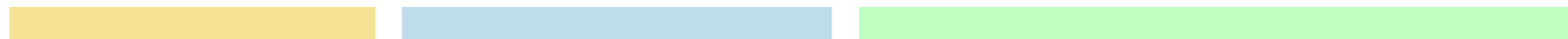

AUDIENCE VIEWS

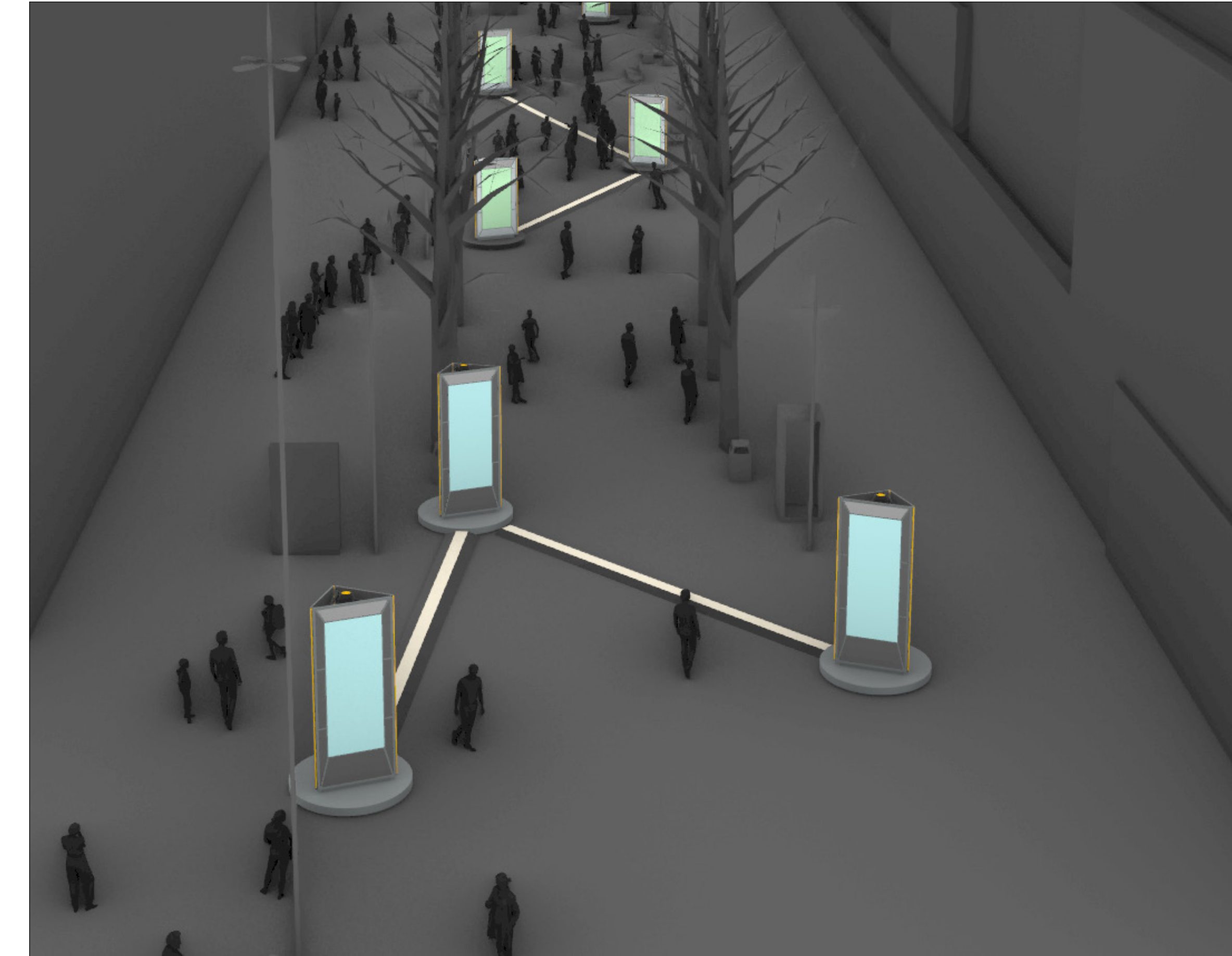

*Left: Audience experience zoning, Whitecard Plan
Right: Audience views, Whitecard*

CREATIVE APPROACH: LED PLINTHS

DESIGNING FOR HUMAN SCALE AND AUDIENCE AREAS

The LED plinths were multi-purpose within the About Us show. Not only were they a key feature in the evening shows, reflecting the human element of the story, they also allowed us to offer a day-time version of the show. This included works produced by local school children, living portraits of local community members and poetry readings created by our partners at The Poetry Society. They were also used as a great marketing tool, showing show information and promotional material for the Unboxed festival.

The plinths not only featured LED but also lighting and sound making them a dynamic storytelling tool.

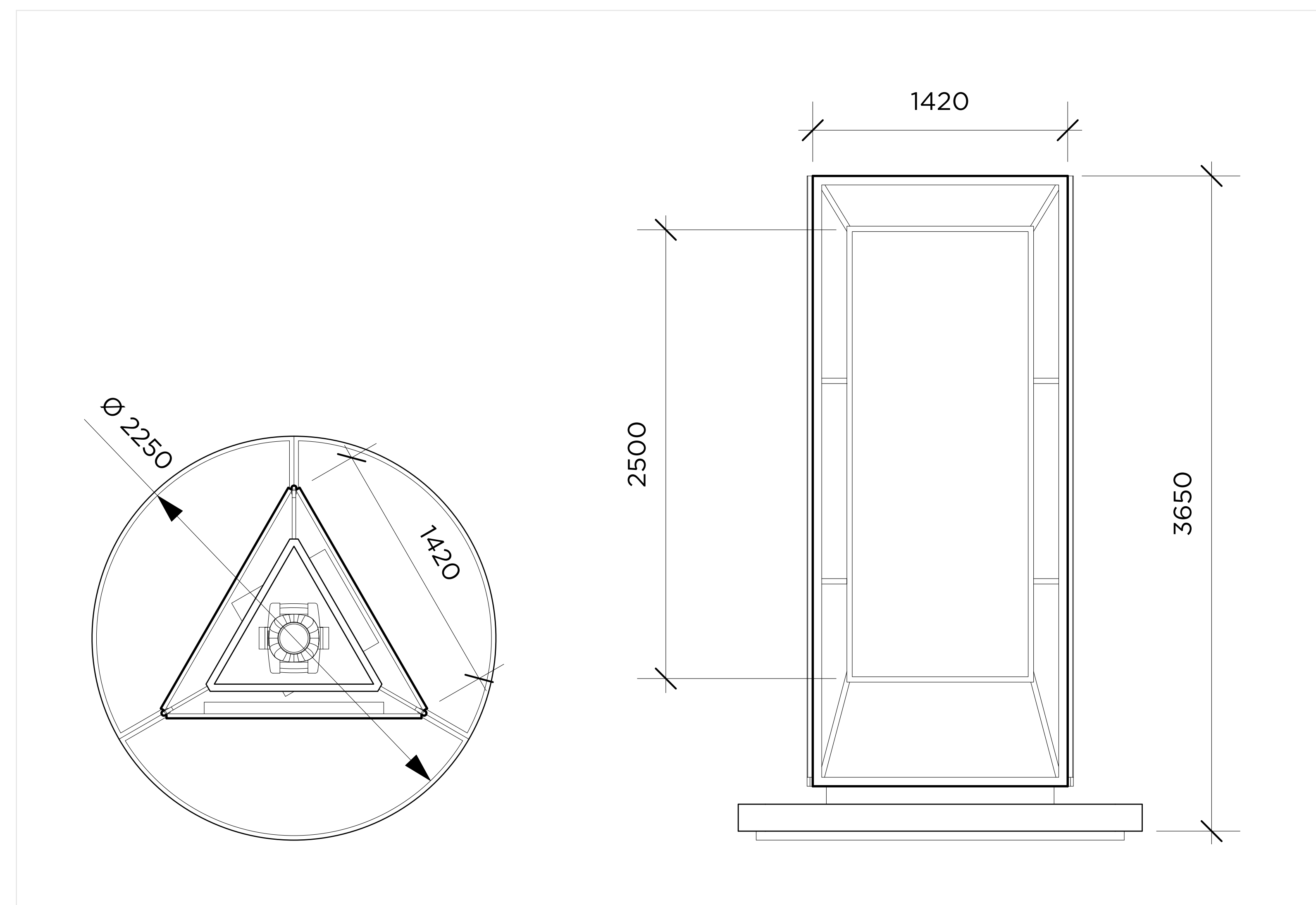

Plan & Elevation, Drawing

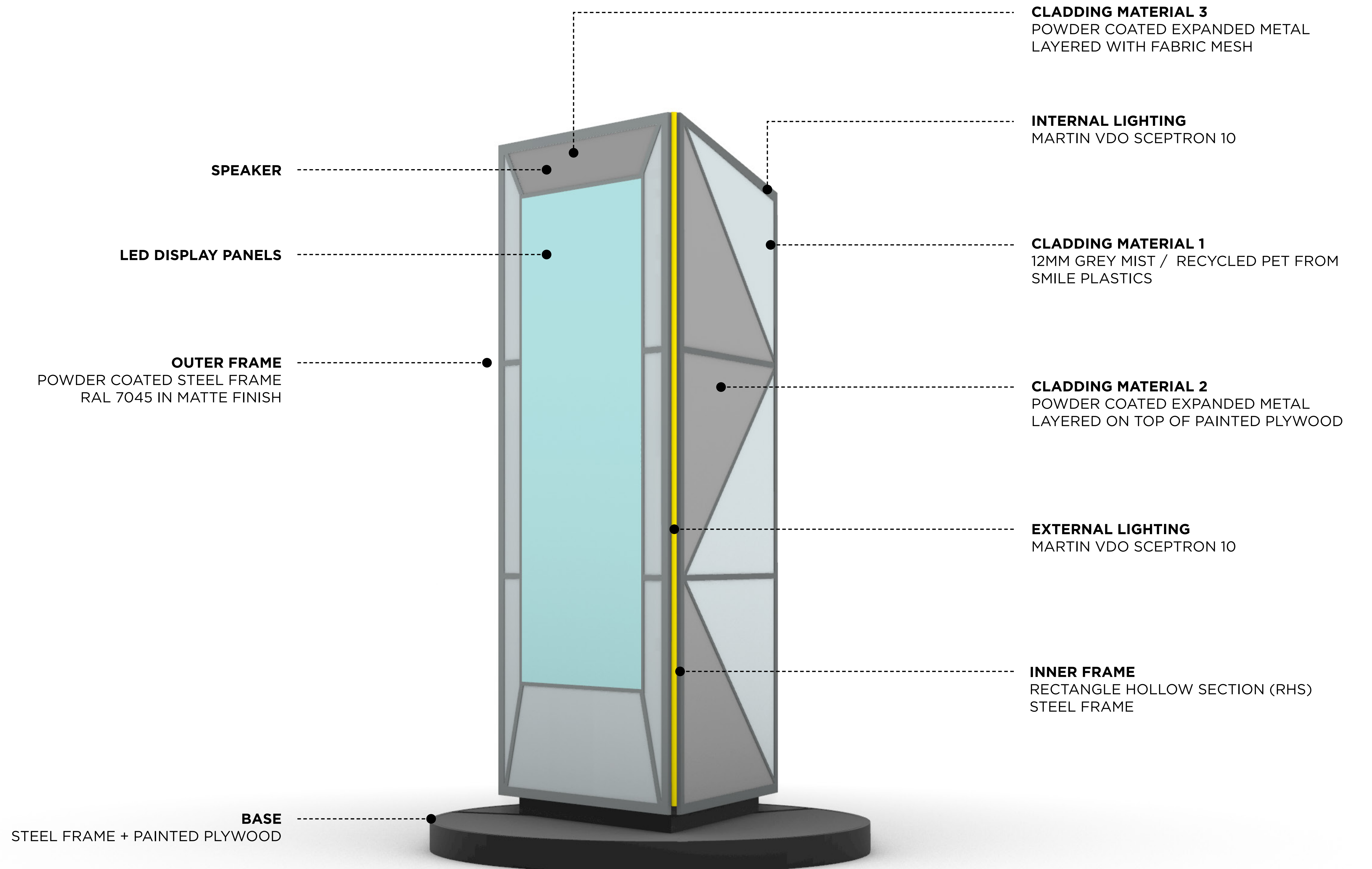

Whitecard plan

PLINTHS

COMPONENTS



1. BASE

- 2250mm diameter base with 125mm in height, hiding cables and ballast in the cavity
- The base can be shipped and lifted into position as fully an assembled piece



2. FRAME

- Welded inner steel structural frame to hold cladding and lighting elements



3. TECHNICAL EQUIPMENT

- 12U Cabinet placed at the bottom
- Speaker placed on top
- Skeptron lighting attached to the outer edge of the plinth



4. FIXED CLADDING

- Triangular panels are held with 25mm aluminium L-angle frame with T-section and 20x20mm steel box
- Two types of cladding is used: Smile plastics and metal mesh with fabric mesh/painted timber



5. ACCESS DOOR

- Side panels are hinged and operable for easy tech access.

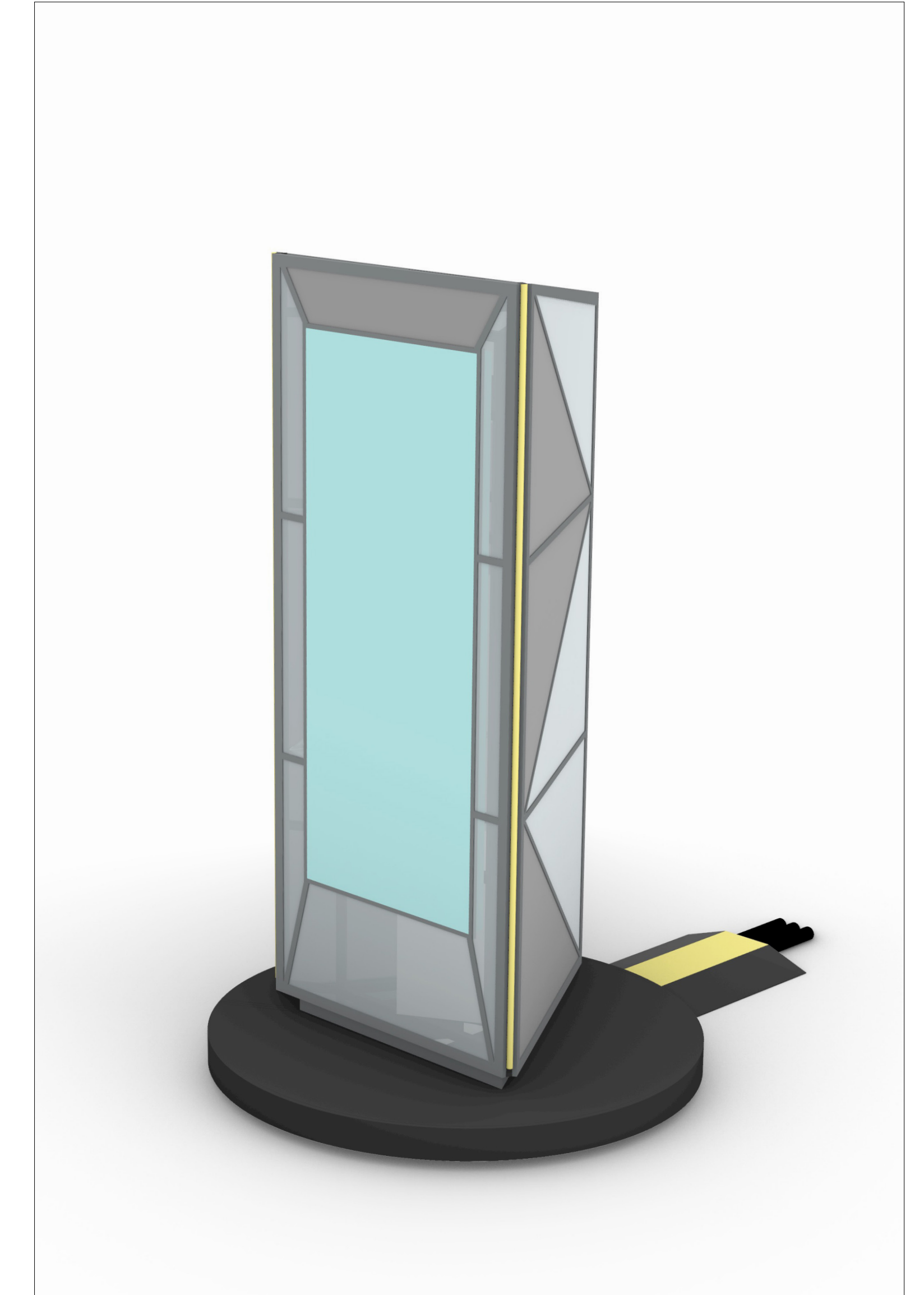

6. FULL ASSEMBLY

- LED panels inserted

CONSTRUCTION

SITE PROGRESS PHOTOGRAPHS



CHOIR

LIVE CHOIR PERFORMANCES

In each location, 59 Productions collaborated with local community choirs to bring to life a score written by Nitin Sawhney, commissioned especially for the project. Working with over 350 singers from a range of backgrounds, with musical direction from Osnat Schmool, the show gave voice to the residents of each town and city, giving a local, human scale aspect to the spectacular visuals.



Choir rehearsal



Choir rehearsal, Paisley



About Us, Live choir performance & projection mapping, Luton



About Us, Live choir performance & projection mapping, Paisley

PROJECTION MAPPING IN 5 LOCATIONS



About Us, Luton, 2022



About Us, Derry-Londonderry, 2022



About Us, Hull, 2022

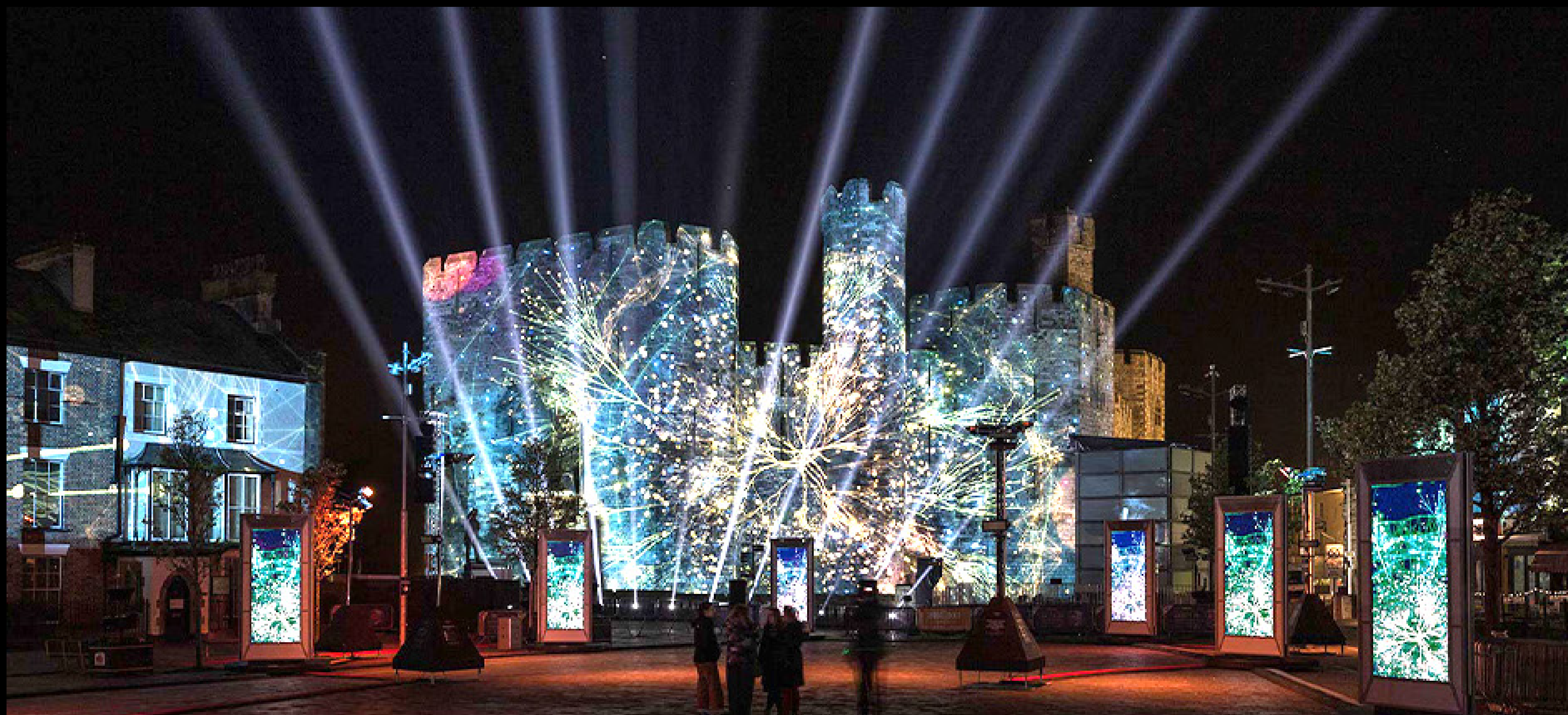

About Us, Caernarfon, 2022



About Us, Paisley, 2022

PROJECTION MAPPING IN 5 LOCATIONS



About Us, Derry-Londonderry, 2022



About Us, Luton, 2022



About Us, Hull, 2022



About Us, Paisley, 2022



About Us, Caernarfon, 2022

PROJECTION MAPPING IN 5 LOCATIONS



About Us, Luton, 2022



About Us, Derry-Londonderry, 2022



About Us, Caernarfon, 2022



About Us, Paisley, 2022



About Us, Hull, 2022

PAISLEY



DERRY~LONDONDERRY



CAERNARFON





HULL



